



**JETRICH CANADA LTD: 3270 Orlando Dr., Mississauga, Ontario, L4V 1C6, CANADA**

Thank you for purchasing the Chris & Chris Chef series kitchen work station.

With proper assembly, maintenance, and cleaning, your work station will give you many years of service.

***NOTE: IF THERE ARE ANY PARTS MISSING; OR THERE IS SLIGHT SHIPPING DAMAGE TO YOUR UNIT, DO NOT RETURN TO THE STORE. PLEASE CONTACT OUR CUSTOMER SERVICE DEPT. FOR HELP, OR VISIT OUR WEBSITE FOR FURTHER INFORMATION.***

CUSTOMER SERVICE: TOLL FREE NUMBER: 1-800-569-4201

E-MAIL: [john@interiorsourcing.com](mailto:john@interiorsourcing.com)

**WEBSITE: [chrisandchrishome.com](http://chrisandchrishome.com)**

ASSEMBLY TIPS: **JET1222 JET3185**“CHEF KITCHEN STATION”

### **TOOLS NEEDED: PHILLIPS HEAD SCREWDRIVER**

- Unpack all parts carefully and inspect
- Cover work surface with soft blanket or similar substance so as not to damage the unit or the work surface.

#### **Step 1**

- Lay top panel Assembly upside down on stable surface
- Locate top (A) and each leg (C). Assemble with bolts (J) per step 1 drawing.
- Do not tighten at this time.

#### **Step 2**

- Slide the “S” Hooks (K) on to the towel bar (E) so that the open ends of the hooks are facing outward. Now mount the towel bars (E) into the holes on either end of top frame (A).
- Secure the towel bar in place using bolts (J). NOTE: THE TOWEL BAR IS MOUNTED OVER THE FLANGE OF LEGS (C) AND SHARE THE SAME MOUNTING HOLES

#### **Step 3**

- Install the 2 basket shelves (B). Note: All bolts can now be tightened. Install the 4 locking casters(BB). Note: if the wheels are in the locked position they are easier to mount

#### **Step 4**

- Turn the cart upright and insert the chef pan (RP) or the trash ring (L). Trash ring (L) can be exchanged for the chef pan (RP) or can be used together

***Congratulations, your Pro Chef work station is ready for action***



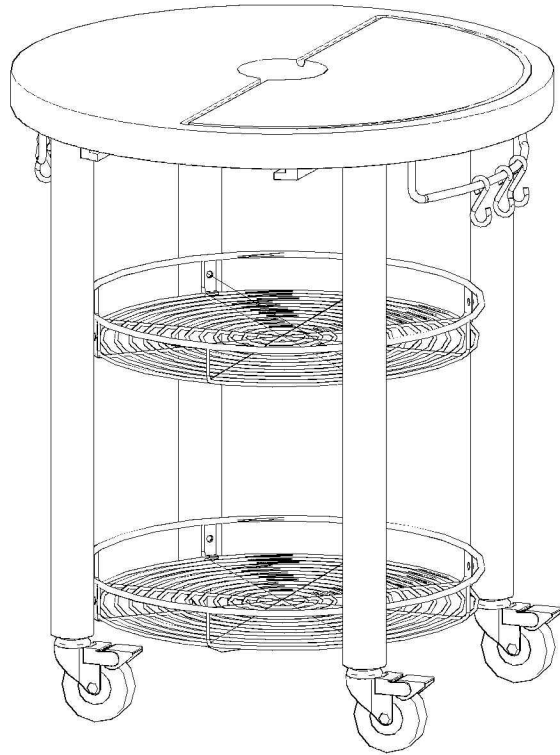

CHEF KITCHEN STATION  
JET 1222 / JET 3185

## ASSEMBLY INSTRUCTION

A. TOP

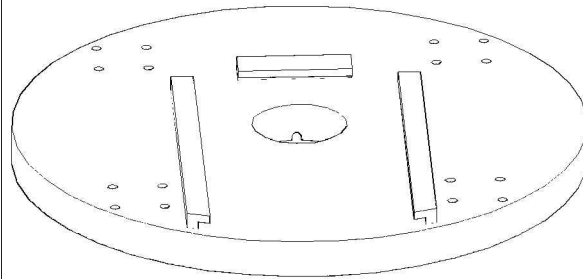

1 EACH

B. BASKET

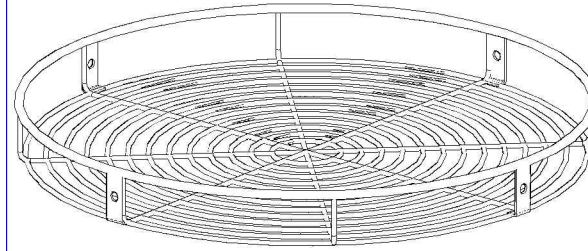

2 EACH

E. TOWER BAR

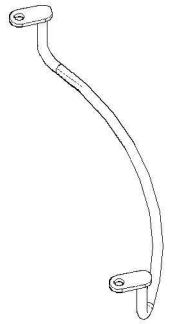

3 EACH

RP. CHEF PAN

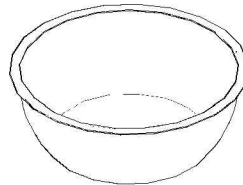

1 EACH

L. TRASH RING

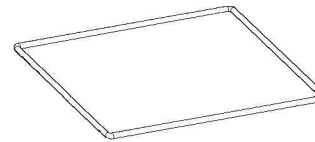

1 EACH

K. "S" HOOK



9 EACH

C. LEGS

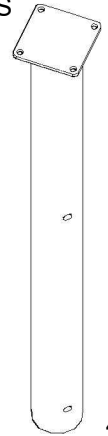

4 EACH

## HARDWARE LIST

BB. BRAKE WHEEL

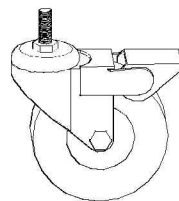

4 EACH

J. BOLT



24 EACH

RM. ALLEN KEY



1 EACH

Q. BIG WRENCH



1 EACH

O. OIL

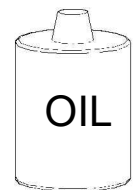

1 EACH

STEP 1

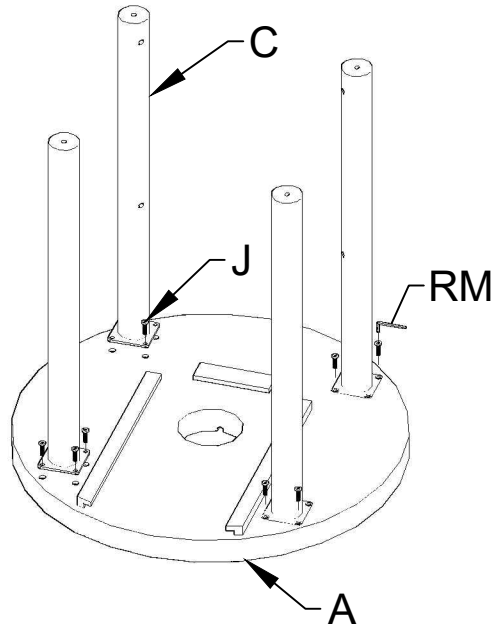

J x 10

STEP 2

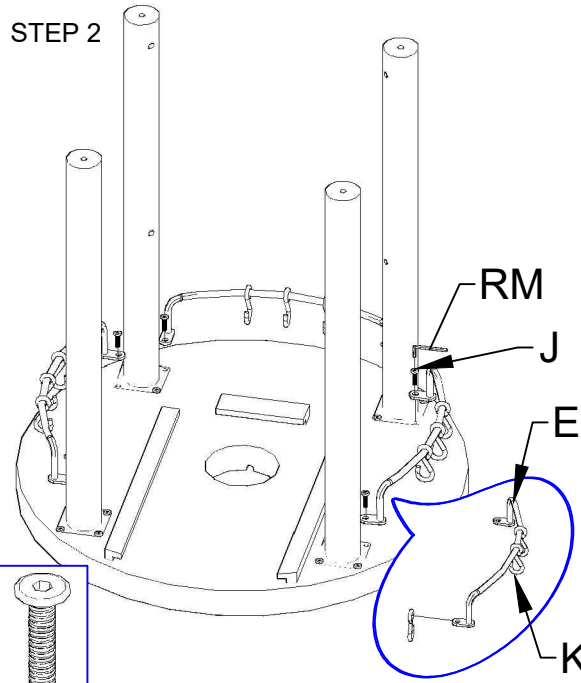

J x 6

STEP 3

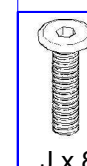
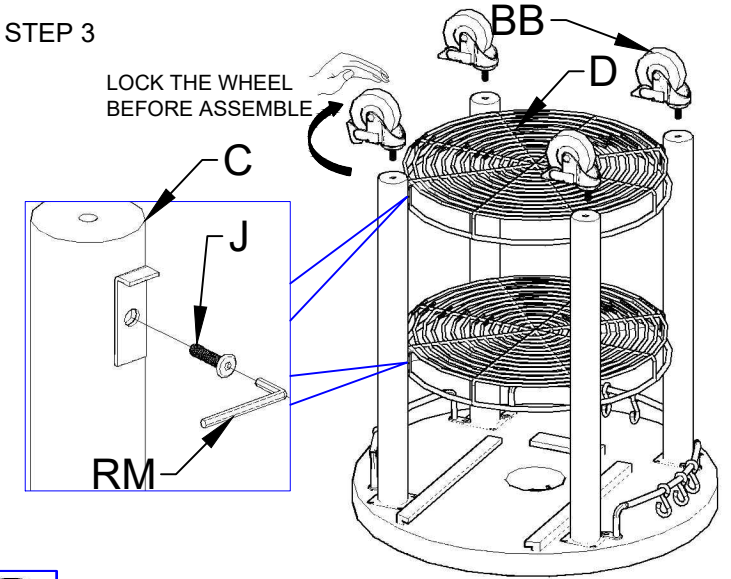

J x 8

STEP 4

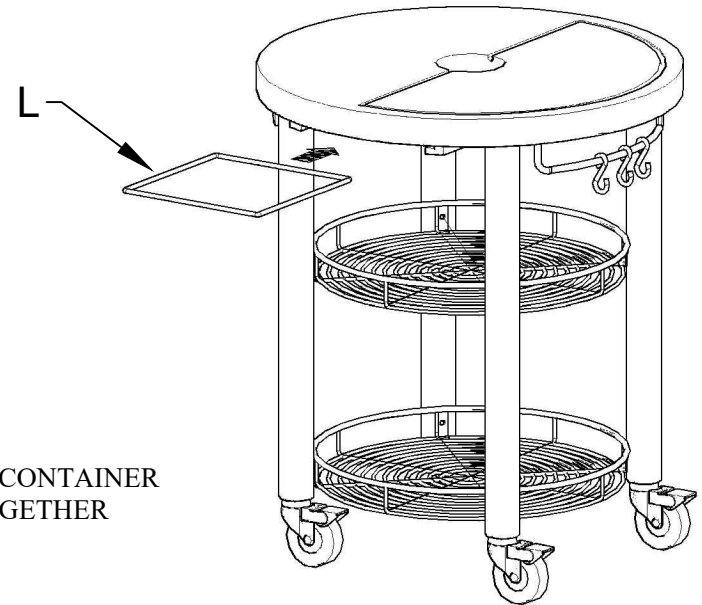
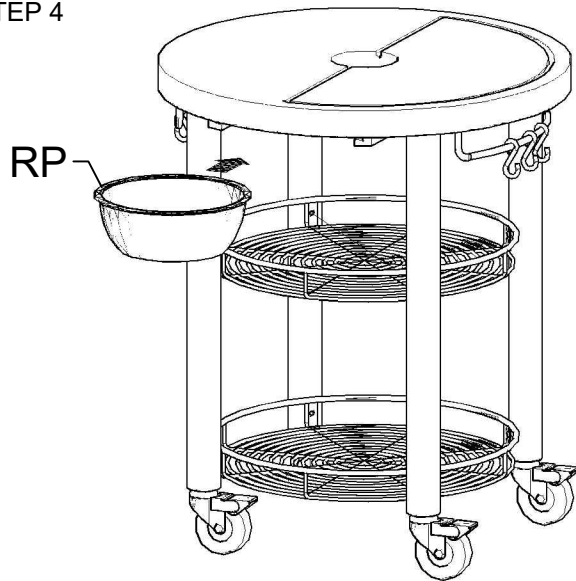

THE WASTE BAG HOLDER AND THE CONTAINER  
CAN BE USED ALTERNATELY OR TOGETHER